

Orientamento RD 270
Position RD 270

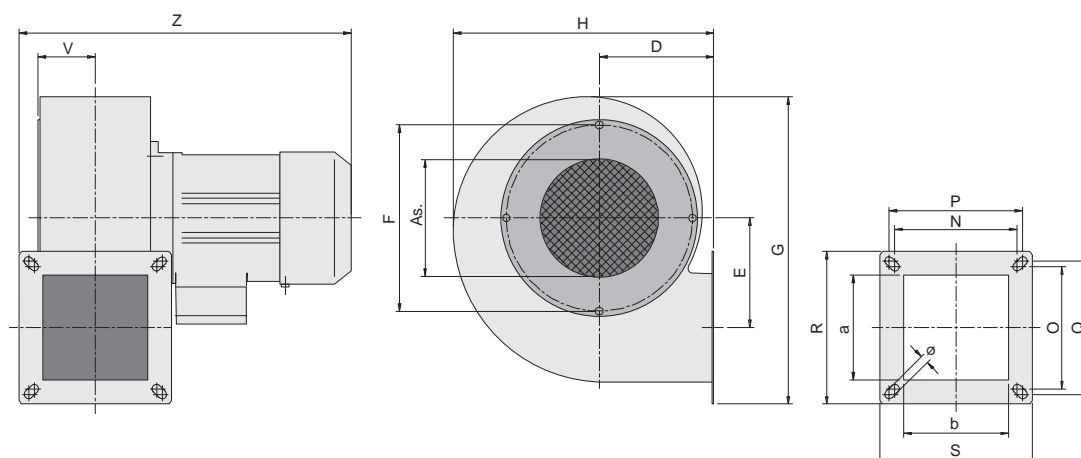

Direzioni di rotazione (vista lato motore) - Rotation senses (seen from motor side)

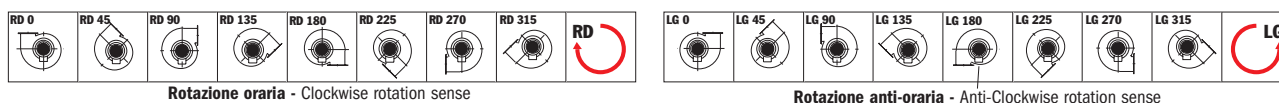

Rotazione oraria - Clockwise rotation sense

Rotazione anti-oraria - Anti-Clockwise rotation sense

Peso ventilatore in Kg (completo di motore) - Weight of ventilator (complete with motor)

Nota: quota Z indicativa - Note: 'Z' quote indicative

TIPO - TYPE		kW inst.	PESO WEIGHT	VENTILATORE FAN																
VENTILATORE FAN	MOTORE MOTOR			kgf	As.	F	D	E	G	H	a	b	N	O	P	Q	φ	R	S	V
MN 202	-	0,09	2,5	85	120	85	62	190	168	60	70	85	75	93	90	7	105	110	39	223
MN 252	-	0,09	3	112	150	100	94	270	223	82	85	110	110	128	128	7	140	140	44	232
MN 302	63 M2	0,18	5,5	112	150	100	94	270	223	85	85	110	110	128	128	7	140	140	47	270
MN 402	63 M2	0,25	6	112	150	100	94	270	223	85	110	128	103	138	115	9	130	155	60	295
MN 502	71 M2	0,37	9,5	122	195	120	115	322	273	110	110	128	128	140	140	9	160	160	60	318
MN 504	63 M4	0,18	6	122	195	120	115	322	273	110	110	128	128	140	140	9	160	160	60	295
MN 552	71 M2	0,55	10	158	195	120	115	322	273	110	110	128	128	140	140	9	160	160	60	318
MN 554	63 M4	0,18	7	158	195	120	115	322	273	110	110	128	128	140	140	9	160	160	60	295
MN 602	80 M2	1,1	20	180	222	156	145	405	338	140	140	160	160	170	170	9	190	190	77	385
MN 604	71 M4	0,25	12	180	222	156	145	405	338	140	140	160	160	170	170	9	190	190	77	338

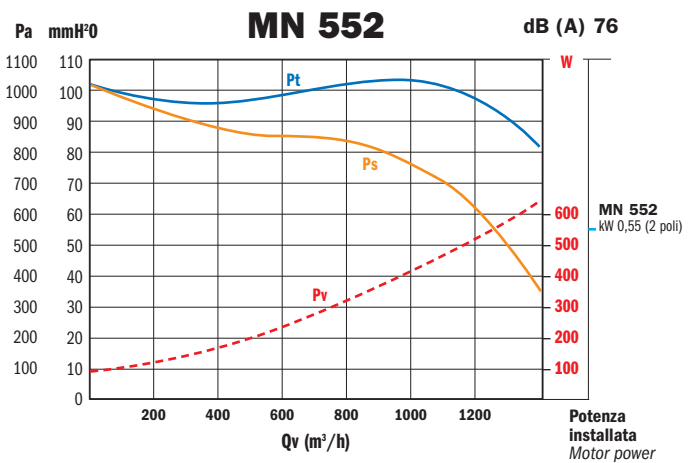
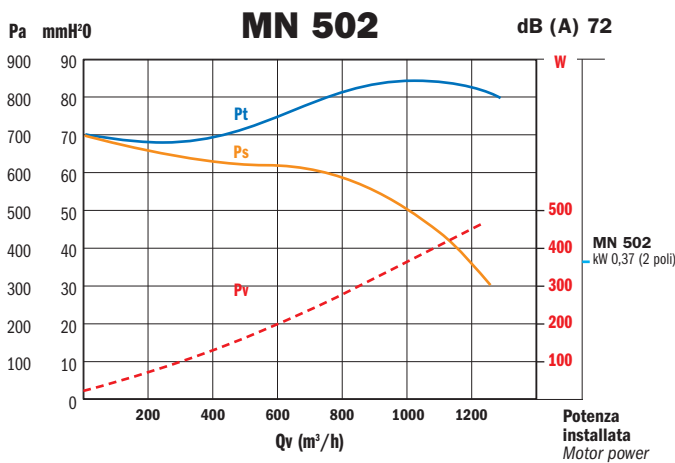
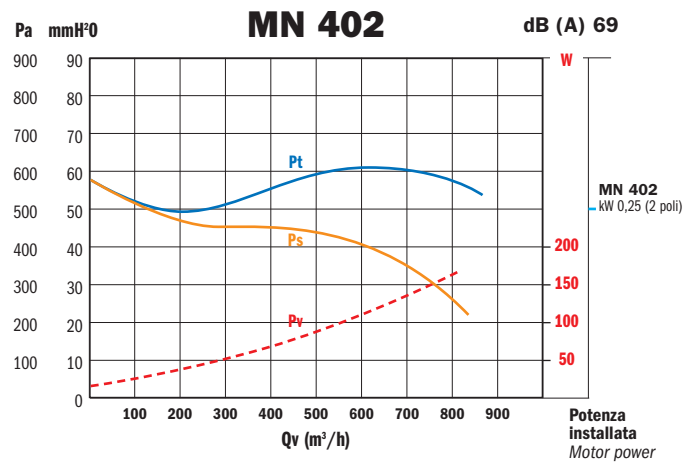
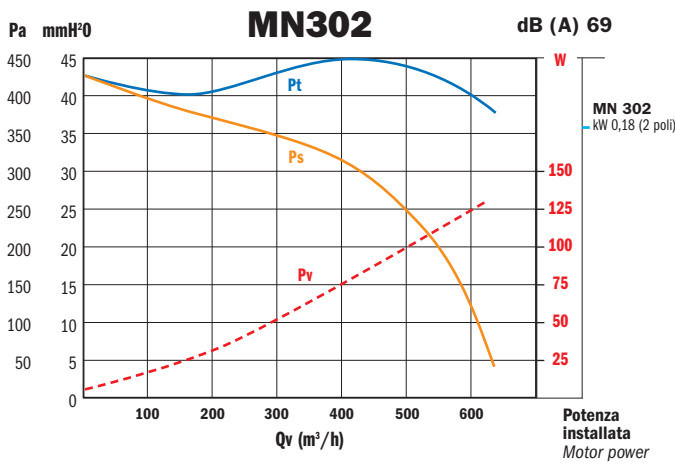
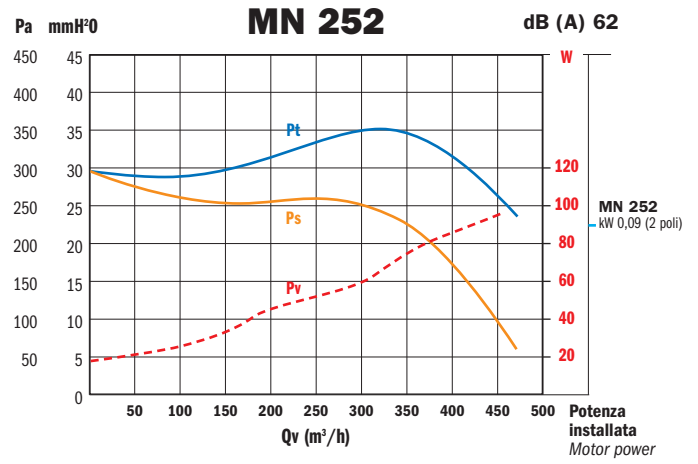
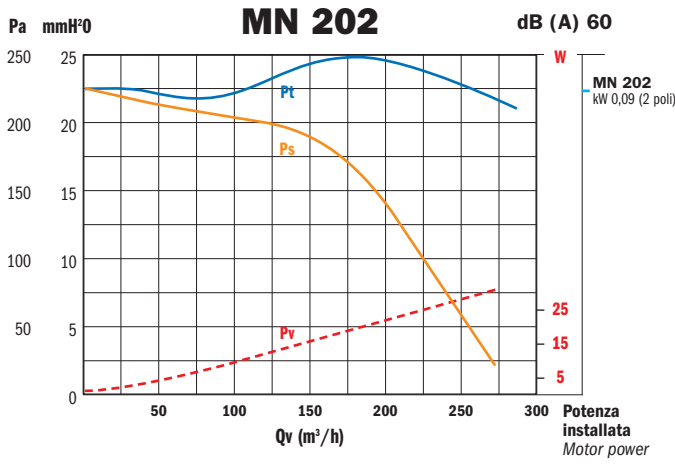

Valori riferiti a: / Datas referring to: T=15°C; P=1 atm

— Pt= Pressione totale - Total pressure — Ps= Pressione statica - Statical pressure - - - Pv= Potenza assorbita - Absorbed power

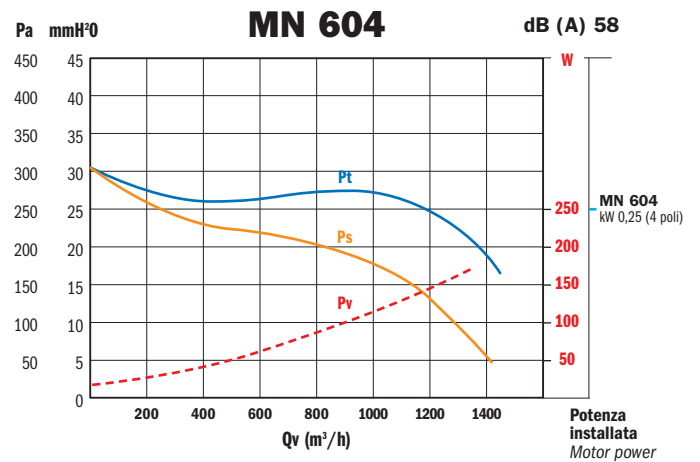
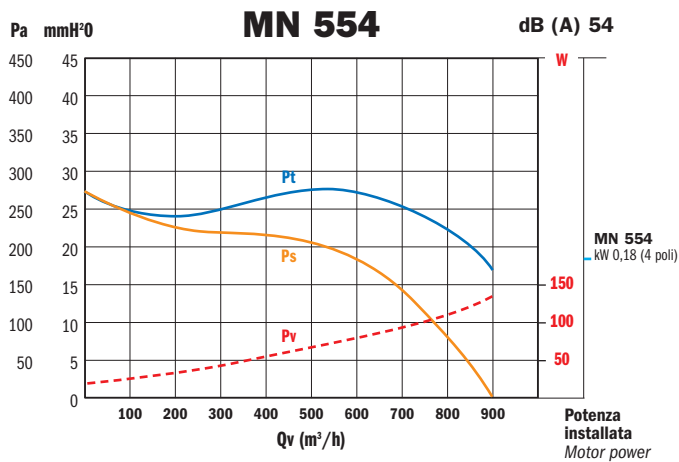
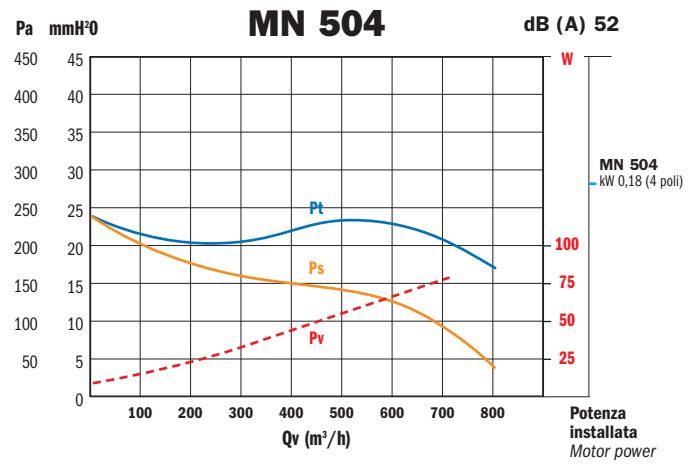
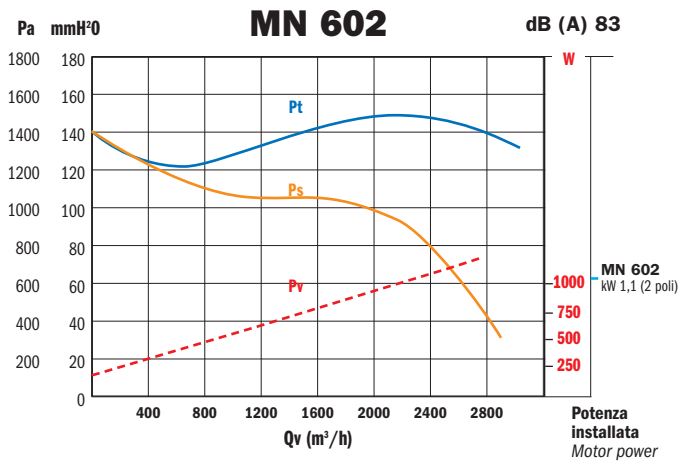

Valori riferiti a:/ Datas referring to: T=15°C; P=1 atm

— Pt= Pressione totale - Total pressure — Ps= Pressione statica - Statical pressure - - - Pv= Potenza assorbita - Absorbed power